

ATTENTION! READ BEFORE INSTALLING!

FOR BEST VISUAL REPRESENTATION OF YOUR FLOOR

This flooring replicates the look of a natural product which has natural variations in color, texture, and sheen/gloss. For best visual effect, shuffle planks or tiles from several cartons and do not install similar planks or tiles next to one another.

SUBFLOOR PREPARATION

Subfloor should be dry and level to 3/16" per 10 ft. radius for best installation results.

Angle-Tap Installation Instructions for COREtec One™ Brand Floors

READ THESE INSTRUCTIONS THOROUGHLY BEFORE BEGINNING INSTALLATION. If the following instructions leave any unanswered questions or if additional information is required, please call USFloors toll free at 800-404-2675 (706-733-6120).

FLOORING MATERIAL SHOULD BE INSPECTED PRIOR TO INSTALLATION

Responsibility for the suitability of USFloors flooring and accompanying products for each individual installation cannot be assumed by USFloors, since USFloors has no control over the installer's proper application. Should an individual plank or tile be doubtful as to appearance or dimension the installer should not use this piece. USFloors will send a replacement in a timely fashion.

NOTE: USFloors COREtec One floors may be installed with a direct glue-down method on approved wooden (or) concrete substrates that are on or above grade only. Use only USFloors Wood and Bamboo Flooring Adhesive (or) comparable premium wood flooring adhesives. Please consult with adhesive manufacturer to determine if suitable for use with this material.

READ BEFORE INSTALLING

While COREtec One is waterproof, it's not a moisture barrier. It's still a good idea to make sure concrete is cured and tested for moisture and that a moisture barrier is installed in the crawl space and even under a COREtec One floor over a concrete subfloor. Moisture won't damage COREtec One, but it can get in the walls and structure of the home. A couple of extra dollars and a few minutes is a small investment for the added protection and peace of mind.

Because houses and buildings, as well as adjacent hardwood or laminate floors, expand and contract, USFloors recommends to leave a 1/4" expansion gap between the perimeter walls and any adjacent hardwood floor.

Do not install COREtec One floors where it will be exposed to temperatures greater than 140° F.

Use good common sense installation practices, and you'll have a successful installation that results in a beautiful floor.

PRE-INSTALLATION JOBSITE REQUIREMENTS

USFLOORS cannot be held responsible for site conditions.

Carefully examine the flooring prior to installation for color, finish, sheen, and quality. Ensure adequate lighting for proper inspection. If flooring is not acceptable, contact your supplier immediately and arrange for a replacement. USFLOORS cannot accept responsibility for flooring installed with visible defects. Prior to installation of any flooring, the installer must ensure that the jobsite and subfloor meet the requirements of these instructions. USFLOORS is not responsible for flooring failure resulting from unsatisfactory jobsite and/or subfloor conditions.

Flooring should be one of the last items installed in any new construction or remodel project.

Crawl spaces must be a minimum of 18" (46 cm) from the ground to the underside of the joists. A ground cover of 6–20 mil black polyethylene film is essential as a vapor barrier. Joints must be lapped 6" (15 cm) and sealed with moisture resistant tape. The crawl space should have perimeter venting equal to a minimum of 1.5% of the crawl space square footage. These vents should be properly located to foster cross ventilation. Where necessary, local regulations prevail.

Room temperature and humidity of installation areas should be consistent with normal, year-round living conditions for at least one week before installation of flooring. Maintaining an optimum room temperature of 70° F and a humidity range of 30-50% is recommended.

PRE-INSTALLATION SUBFLOOR REQUIREMENTS

All Subfloors must be:

- Dry
- Structurally sound
- Clean: Thoroughly swept and free of all debris
- Level: Flat to 3/16" per 10-foot radius

Wood subfloors must be dry and well secured. Nail or screw every 6" along joists to avoid squeaking. If not level, sand down high spots and fill low spots with a Portland-based leveling patch.

Concrete subfloors must be fully cured, at least 60 days old, and 6-mil polyfilm is recommended between concrete and ground. Subfloor should be flat and level within 3/16" per 10' radius. If necessary grind high spots down and level low spots with a Portland leveling compound.

Ceramic tile, resilient tile and sheet vinyl must be well-bonded to subfloor, in good condition, clean, and level. Do not sand existing vinyl floors, as they may contain asbestos.

**This floor can
be installed on
all levels of the
home.**

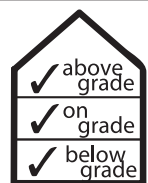

INSTALLATION TOOLS

For all installation methods:

Tape measure	Pencil	Chalk Line	Crosscut Power Saw	3M Scotch Blue™ 2080 Tape
¼" Spacers	Hammer	Tapping Block	Pull Bar	

Acceptable subfloor types:

CDX Underlayment Grade Plywood (at least ½" thick)	Underlayment Grade Particleboard	
OSB (at least ¾" thick)	Concrete Slab	Existing Wood or Laminate Floor
Ceramic Tile	Resilient Tile	Sheet Vinyl

STARTING YOUR INSTALLATION

Because houses and buildings, as well as adjacent hardwood or laminate floors, expand and contract, USFloors recommends leaving a ¼" expansion gap between the perimeter walls and any adjacent hardwood floor.

Work from several open boxes of flooring and "dry lay" the floor before permanently laying the floor. This will allow you to select varying textures, colors, and sheens, and to arrange them in a harmonious pattern. Remember, it is the installers' responsibility to determine the expectations of what the finished floor will look like with the end user first and then to cull out pieces that do not meet those expectations.

Begin installation next to an outside wall. This is usually the straightest and best reference for establishing a straight working line. Establish this line by measuring an equal distance from the wall at both ends and snapping a chalk line. The distance you measure from the wall should be the width of a plank or tile. You may need to scribe cut the first row of planks or tiles to match the wall in order to make a straight working line if the wall is out of straight.

You may want to position a few rows before starting installation to confirm your layout decision and working line.

When laying flooring, stagger end joints from row to row by at least 8" (20 cm) for planks, and equal to 12" (51 cm or a half piece) for tiles. For plank installations, you can use the cut-off end to begin the next row when cutting the last plank in a row to fit. If cut-off end is less than 8", discard it and instead cut a new plank at a random length (at least 8" in length) and use it to start the next row. For tile installations, always begin a row with either a full tile or a half tile so that the joints are consistently staggered in a "brick work" type pattern. Always begin each row from the same side of the room.

INSTALLATION INSTRUCTIONS

Inspection: Prior to installation, inspect material in daylight for visible faults/damage. Check if subfloor/site conditions comply with the specifications described in these instructions. If you are not satisfied, do not install, and contact your supplier.

Before laying: Measure the room at right angle to the direction of the flooring. For the best visual effect, planks or tiles in the final row should be at least at least 1/3 the width of the plank or tile. For this purpose, planks or tiles in the first row can be cut to smaller size. Shuffle boards in order to obtain a pleasant blend of shades. Lay boards, preferably following the direction of the main source of light. We recommend laying on wooden floors crossways to the existing floorboards.

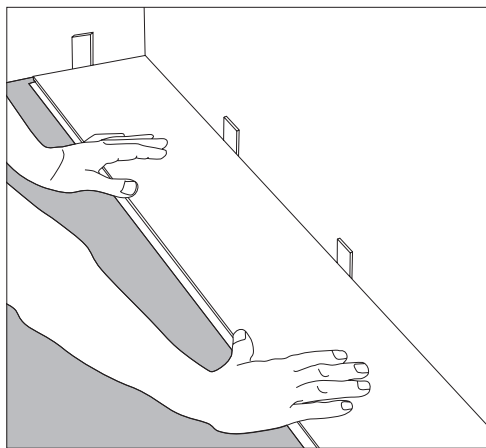

Step 1: Begin installation working from left to right. Insert spacers at ends and edges where planks meet wall.

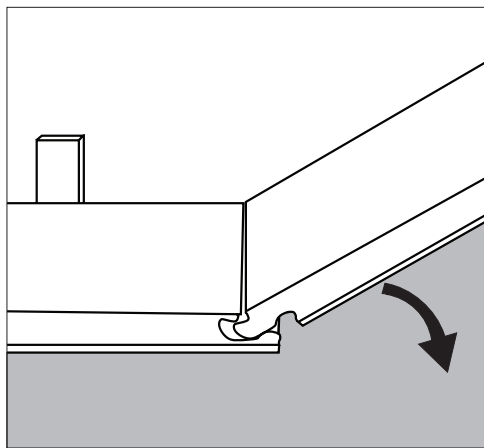

Step 2: Lock short end of plank by inserting tongue into groove at an angle and drop in place. Continue to end of first row.

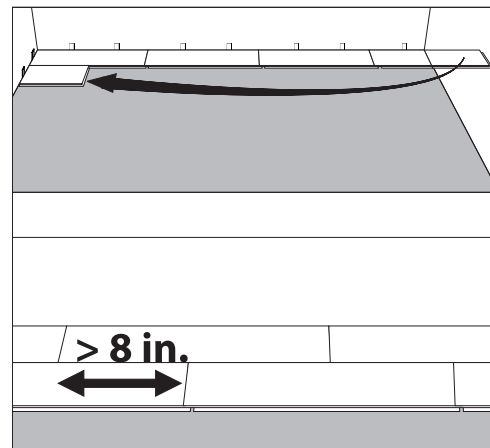

Step 3: Use leftover plank from first row as starter for second row. There must be at least 8" between plank end joints on adjacent rows.

FOR TILE INSTALLATIONS: The distance between end joints should be equal to 12" for proper appearance.

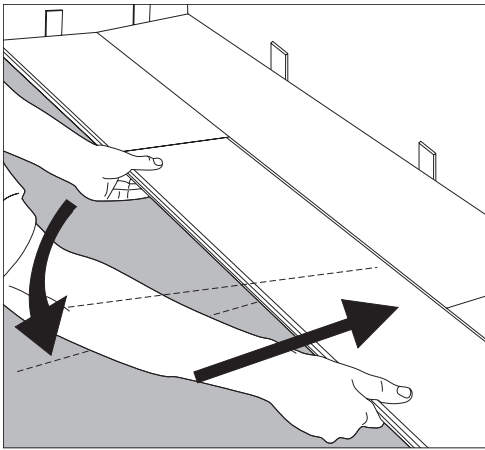

Step 4: Lock long edge of plank by inserting tongue into groove at an angle and drop in place. Slide plank toward end of previously installed plank until the tongue just touches the groove.

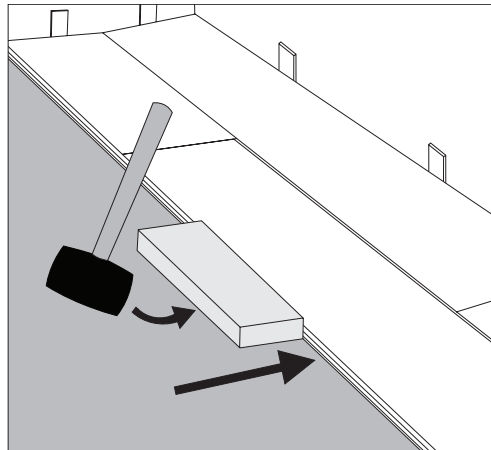

Step 5: IMPORTANT! Use hammer and tapping block to tap long edge of plank to ensure a tight fit. **ANY GAPPING CAN COMPROMISE THE LOCKING SYSTEM!**

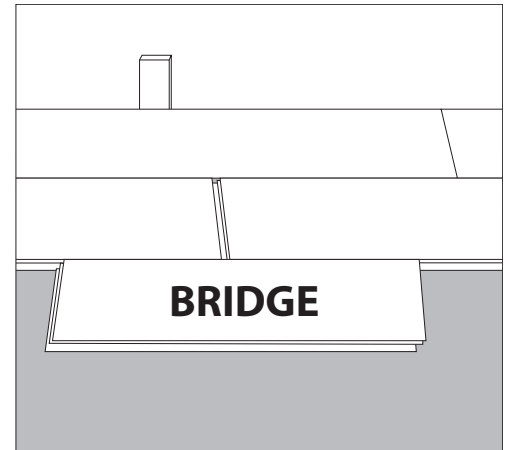

Step 6: Attach a scrap piece of floor to bridge gap between ends of planks.

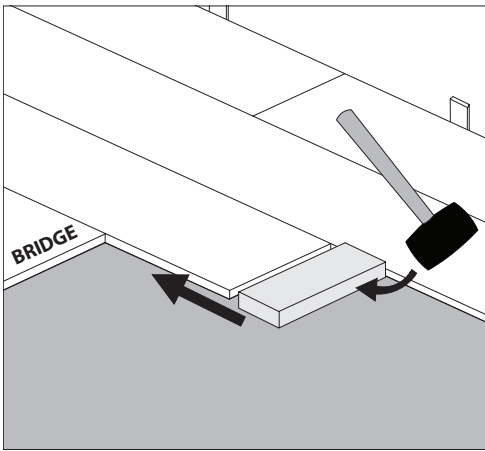

Step 7: Tap end of plank with hammer and tapping block to lock ends of planks together. Remove bridge and continue towards wall until installing the final plank in the row. **BE SURE TO TAP ON EDGE OF VINYL SO AS NOT TO DAMAGE LOCKING PROFILE.**

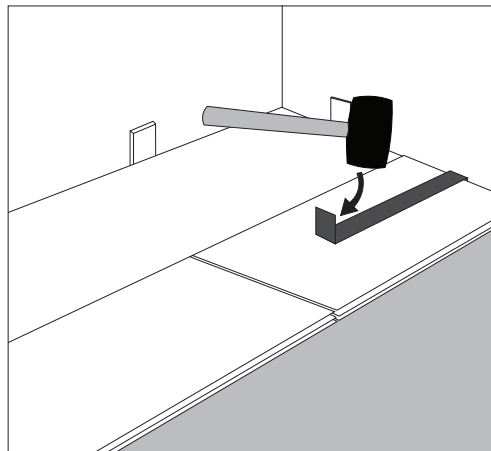

Step 8: Use hammer and pull bar to lock final piece in row. Insert spacer at end of row. Continue installation to final row.

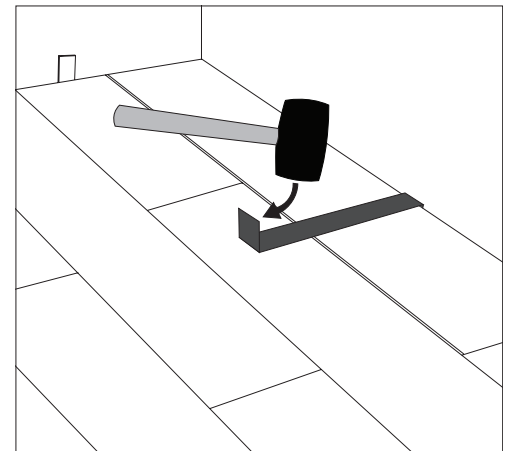

Step 9: Use hammer and pull bar to lock long edges of planks on final row.

INSTALLING UNDER DOOR JAMBS:

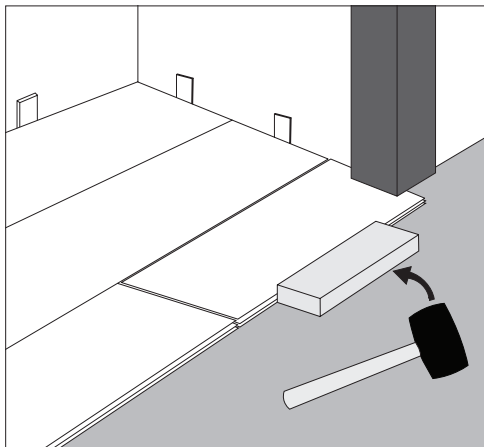

Step 1: Undercut space under door jamb to allow plank to slide freely. Tap long edge with hammer and tapping block to lock long edge.

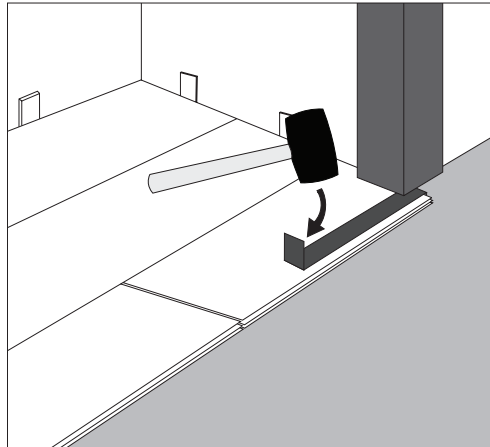

Step 2: Use hammer and pull bar to lock short end of plank.

In-floor Radiant Heat:

COREtec One can be installed over radiant heat using the floating or glue down method. When gluing floor, use only USFloors recommended adhesive over manufacturer's recommended substrate.

- Turn the heat off for 24 hours before, during and 24 hours after installation when installing over radiant heated subfloors
- Floor temperature must not exceed 85°F (30°C).
- Failure to strictly follow adhesive manufacturer's guidelines may result in failure and void the warranty.

Warning: Electric heating mats that are not embedded into the subfloor are not recommended for use underneath COREtec One floors. Using electric heating mats that are not embedded and applied directly underneath COREtec One floors could void the warranty for your floor in case of failure. It is best to install COREtec One flooring over embedded radiant floor heating systems and adhere to the guidelines listed above.

AFTER INSTALLATION

- Flooring should be one of the last items installed in a project. In order to protect the floors while other trades are finishing their work prior to final cleanup and turnover to the owner, use rosin paper and only use 3M Scotch-Blue™ 2080 Tape to hold the rosin paper to the floor (other blue tapes may damage the finish). Clean the floor thoroughly before laying the rosin paper to ensure that no debris is trapped underneath. **DO NOT USE** plastic film or other non-breathing coverings as this can cause the floor to become damaged from humidity buildups.
- Dust-mop or vacuum your floor to remove any dirt or debris.
- It is suggested that you clean the floor using a recommended ph neutral cleaner available at www.1877floorguy.com/usflcoplevp.html.
- Install any transition pieces that may be needed (reducers, T-moldings, etc.).

Protection and Maintenance of Your Floor

Lasting beauty can be achieved through purchasing a quality floor covering and providing proper on-going maintenance.

- Furniture should be moved onto the newly installed floor using an appliance hand truck over hardboard runways.
- Avoid exposure to long periods of direct sunlight. Close blinds or drapes during peak sunlight hours. Floor covering subjected to excessive heat and light is subject to thermal degradation. Use appropriate precautions to minimize potential effects on the floor covering.
- Do not expose COREtec One floors to temperature exceeding 140° F.
- Oil or petroleum-based products can result in surface staining. Do not track asphalt-driveway sealer or automobile-oil drips onto the vinyl floor covering.
- Caster wheeled chairs should have wide, rubber casters. Protective mats are required under office chairs.
- Use non-staining mats. Rubber may discolor the floor.
- Frequently moved furniture should be equipped with felt pads to avoid scratching the floor. Heavy furniture and appliances should be equipped with non-staining large surface floor protectors. Furniture with castors or wheels must be easy swiveling, large surface non-staining and suitable for resilient floors. Do NOT use ball type castors as they can damage the floor.
- Use floor protectors under furniture.
- Use walk off mats at entrances to prevent dirt and grit from being tracked on to the floor.
- Sweep or vacuum the floor regularly to remove loose dirt. Do NOT use vacuums that use a beater bar or turn beater bar off.
- Do NOT use electric brooms with hard plastic bottoms with no padding.
- Clean up spills immediately.
- Damp mop as needed using clean water and a diluted floor cleaner. Do NOT use harsh cleaners or chemicals on the floor. Do NOT use abrasive scrubbing tools. Do NOT use detergents, abrasive cleaners or "mop and shine" products.
- Vinyl flooring, like other types of smooth floors, may become slippery when wet. Allow time for floor to dry after cleaning. Immediately wipe up wet areas from spills, foreign substances or wet feet.

For complete maintenance guidelines for your floor visit www.usfloorsllc.com.